

Istruzioni / Instructions / Instructions De Montage / Bedienungsanleitung / Instrucciones

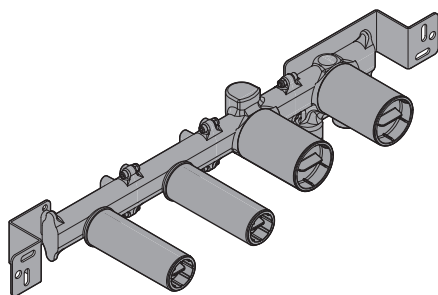

IFEZ027

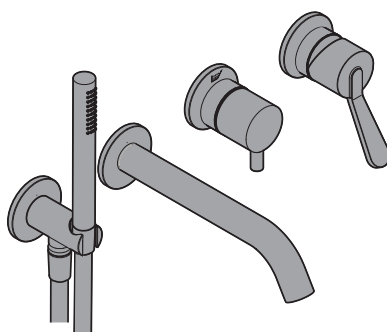

EFEZ027

IFEZ027

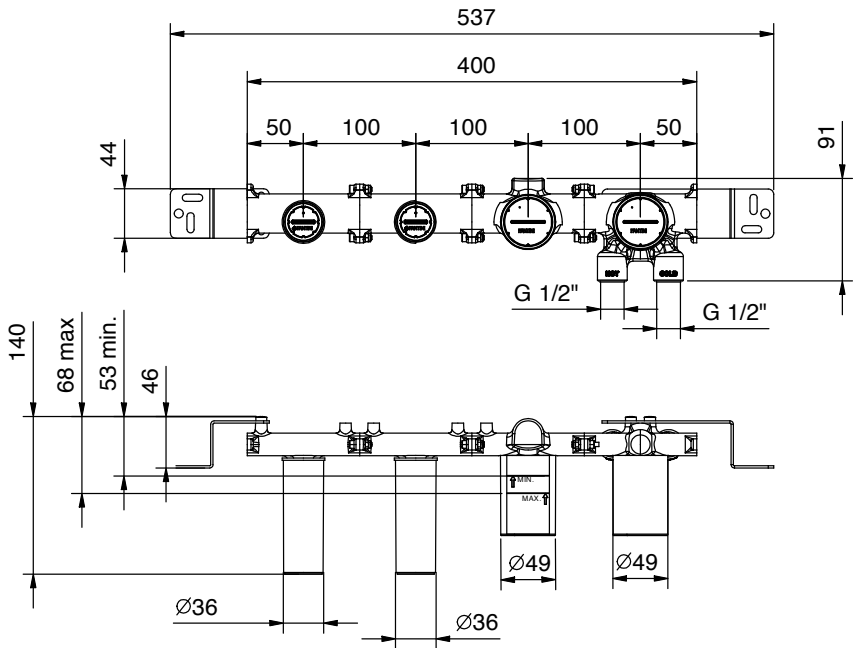

- IT** Questi miscelatori possono essere utilizzati con accumulatori di acqua calda a pressione o con scaldabagni istantanei.
- EN** These mixers can be used with high-pressure hot water accumulators or with instant water heaters.
- FR** Ces mitigeurs peuvent être utilisés avec des accumulateurs d'eau chaude à pression ou avec des chauffe-eau instantanés.
- DE** Diese Mischer sind sowohl für Heißwasserspeicher als auch Durchlauferhitzer geeignet.
- ES** Estos monomandos pueden utilizarse con acumuladores de agua caliente a presión o con calentadores instantáneos.
- PT** Esta misturadora pode ser utilizada com acumuladores de água quente sob pressão ou com esquentadores instantâneos.

EFEZ027

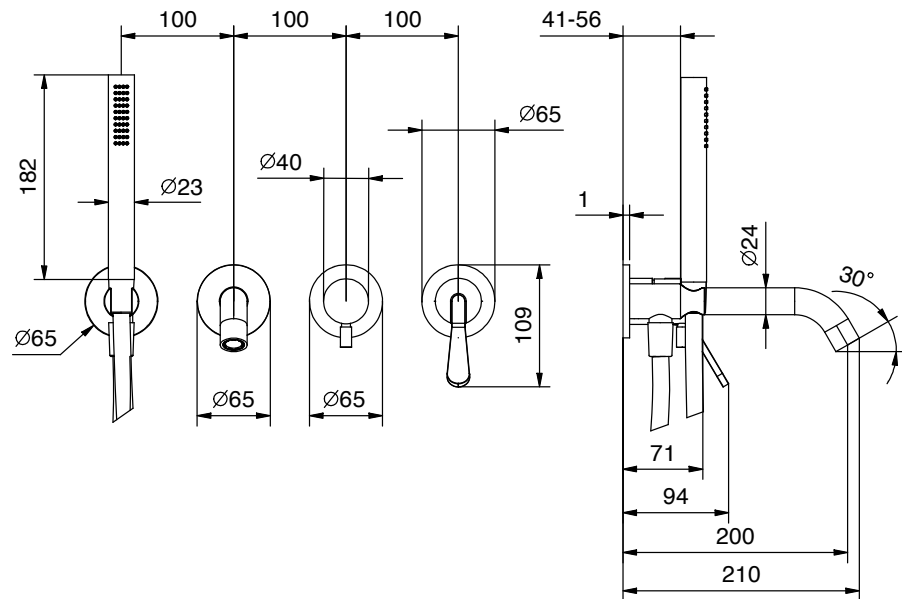

- IT** Questi miscelatori possono essere utilizzati con accumulatori di acqua calda a pressione o con scaldabagni istantanei.
- EN** These mixers can be used with high-pressure hot water accumulators or with instant water heaters.
- FR** Ces mitigeurs peuvent être utilisés avec des accumulateurs d'eau chaude à pression ou avec des chauffe-eau instantanés.
- DE** Diese Mischer sind sowohl für Heißwasserspeicher als auch Durchlauferhitzer geeignet.
- ES** Estos monomandos pueden utilizarse con acumuladores de agua caliente a presión o con calentadores instantáneos.
- PT** Esta misturadora pode ser utilizada com acumuladores de água quente sob pressão ou com esquentadores instantâneos.



IT

EN

FR

Pressione minima	Minimum pressure	Pression minimum	1 BAR
Pressione massima	Maximum pressure	Pression maximum	10 BAR
Press. di esercizio consigliata	Reccomended working pressure	Pression optimale de service	2-5 BAR
Temperatura massima	Max. water temperature	Température maximum	80° C 176° F
Temperatura massima consigliata	Maximum water temperature recommended	Température maximum optimale	65° C 149° F
Differenza max di pressione in arrivo (calda - fredda)	Maximum in-let pressure difference (hot - cold) 1.5 BAR	Différence max. de pression d'arrivée (chaud - froid)	1.5 BAR

DE

ES

PT

Minimum druck	Pression mínima	Pressão mínima	1 BAR
Höchste druck	Pression máxima	Pressão máxima	10 BAR
Empfehlener druck	Pression de trab. aconsejada	Press. de funcionamento recomendada	2-5 BAR
Höchste wasser Temperatur	Temperatura máxima	Temperatura máxima	80° C 176° F
Wassertemperatur Höchste einkommende	Temperatura máxima aconsejada	Temperatura máxima recomendada	65° C 149° F
Höchste einkommende Drucksunterschied (Warm - kalt)	Diferencial max. de presiùn de entrada (caliente - fria)	Diferença máxima de pressão na entrada (quente - fria)	1.5 BAR

- IT** Se la pressione dell'acqua è superiore a 5 bar, è preferibile installare un riduttore di pressione a monte dell'alimentazione per evitare vibrazioni e rendere regolare la regolazione della temperatura.
- EN** If water pressure is above 5 bar, it is advisable to install a flow restrictor upstream of the water supply to avoid vibrations and regulate temperature.
- FR** Si la pression de l'eau est supérieure à 5 bar, il est recommandé d'installer un réducteur de pression en amont de l'alimentation afin d'éviter toute vibration et régulariser le réglage de la température.

- DE** Wenn der Wasserdruck über 5 bar liegt, sollte möglichst ein Druckminderer vor der Zuleitung montiert werden, um Schwingungen zu vermeiden und eine gleichmäßige Temperaturregelung zu ermöglichen.
- ES** Si la presión del agua supera los 5 bar, es preferible instalar un limitador de caudal en la conducción de la alimentación para evitar vibraciones y normalizar la regulación de la temperatura.
- PT** Se a pressão da água for superior a 5 bar, é preferível instalar um redutor de pressão antes do abastecimento para evitar vibrações e tornar a regulação da temperatura regular.

UTENSILI NECESSARI - NECESSARY TOOLS - OUTILS NÉCESSAIRES
 ERFORDERLICHE WERKZEUGE - HERRAMIENTAS NECESARIAS - FERRAMENTAS NECESSÁRIAS

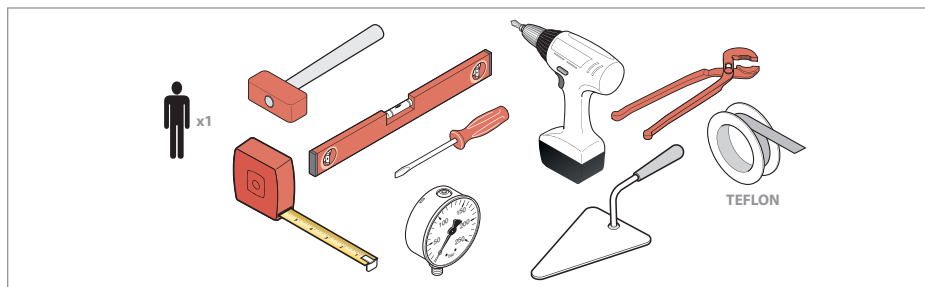



IFEZ027

FASI DI MONTAGGIO - ASSEMBLY PHASES
PHASE D'ASSEMBLAGE - MONTAGEPHASEN
FASES DE MONTAJE - FASES DE MONTAGEM

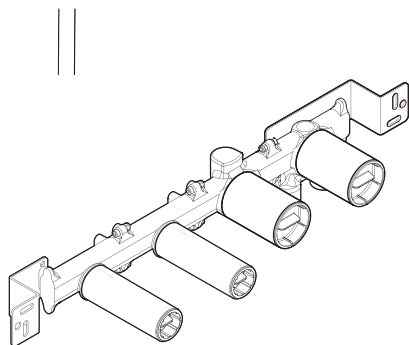

1A	1B	3	4
5	6		

EFEZ027

FASI DI MONTAGGIO - ASSEMBLY PHASES
PHASE D'ASSEMBLAGE - MONTAGEPHASEN
FASES DE MONTAJE - FASES DE MONTAGEM

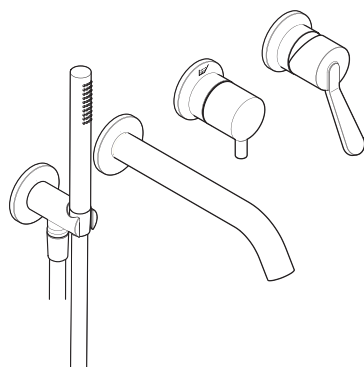

7	8	9	10
11	12	13	14
15	16	17	18
19	20	21	22
23	24	25	26
27			

IFEZ027

INSTALLAZIONE SU MURATURA
 INSTALLING ON BRICKWORK
 INSTALLATION SUR MUR
 INSTALLATION AUF MAUERWERK
 INSTALACIÓN EN ALBAÑILERÍA
 INSTALAÇÃO EM PAREDE DE ALVENARIA

1A

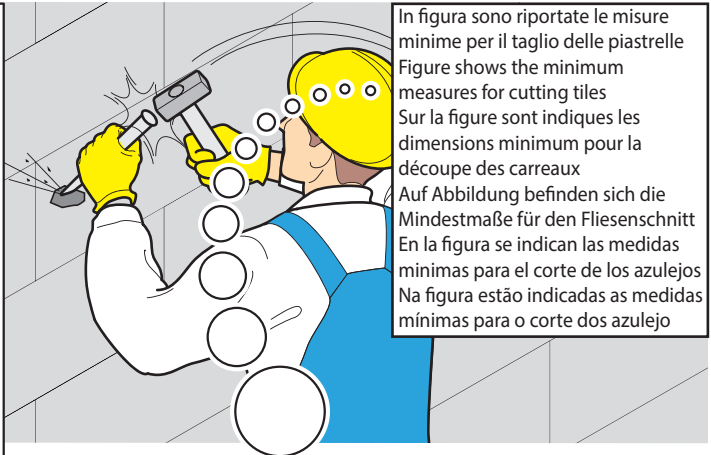
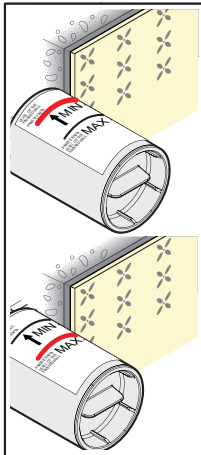
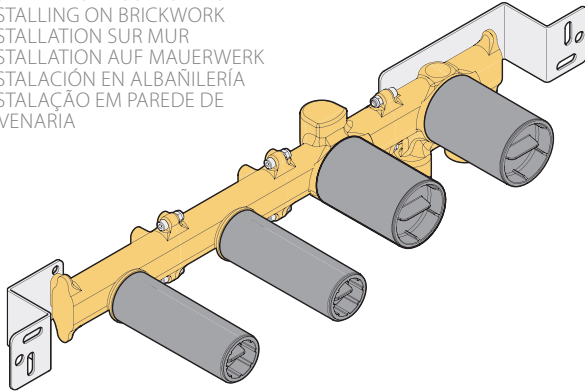

In figura sono riportate le misure minime per il taglio delle piastrelle
 Figure shows the minimum measures for cutting tiles
 Sur la figure sont indiqués les dimensions minimum pour la découpe des carreaux
 Auf Abbildung befinden sich die Mindestmaße für den Fliesenschnitt
 En la figura se indican las medidas mínimas para el corte de los azulejos
 Na figura estão indicadas as medidas mínimas para o corte dos azulejo

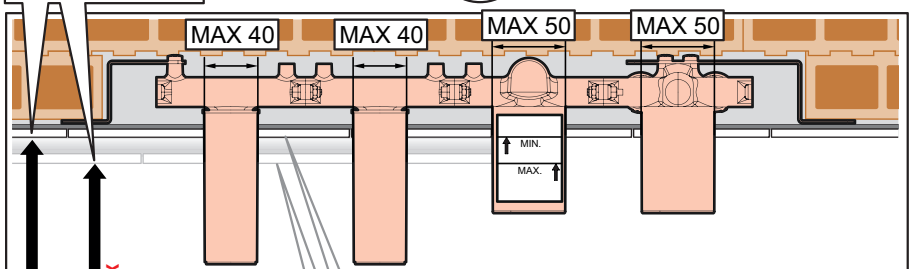

MIN
MAX
 Filo rivestimento
 Edge of the tiling
 Fil revetment
 Verkleidungskante
 Borde revestimiento
 Alinhamento do revestimento

MIN= profondità minima / minimum depth / profondeur minimale
 minimale tiefe / profundidad mínima / profundidade mínima
 MAX= profondità massima / maximum depth / profondeur maximale
 maximale tiefe / profundidad máxima / profundidade máxima

1B

INSTALLAZIONE SU CARTONGESSO
 INSTALLING ON PLASTERBOARD
 INSTALLATION SUR PLACOPLÂTRE
 INSTALLATION AUF GIPSKARTON
 INSTALACIÓN EN CARTÓN-YESO
 INSTALAÇÃO EM PLACA DE GESSO

In figura sono riportate le misure minime per il taglio delle piastrelle

Figure shows the minimum measures for cutting tiles

Sur la figure sont indiqués les dimensions minimum pour la découpe des carreaux

Auf Abbildung befinden sich die Mindestmaße für den Fliesenschnitt

En la figura se indican las medidas mínimas para el corte de los azulejos

Na figura estão indicadas as medidas mínimas para o corte dos azulejo

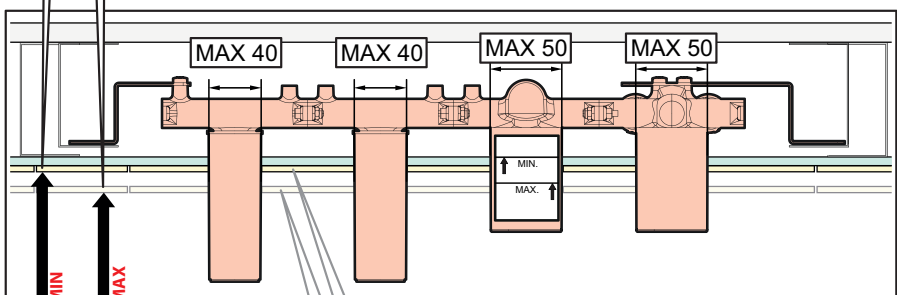
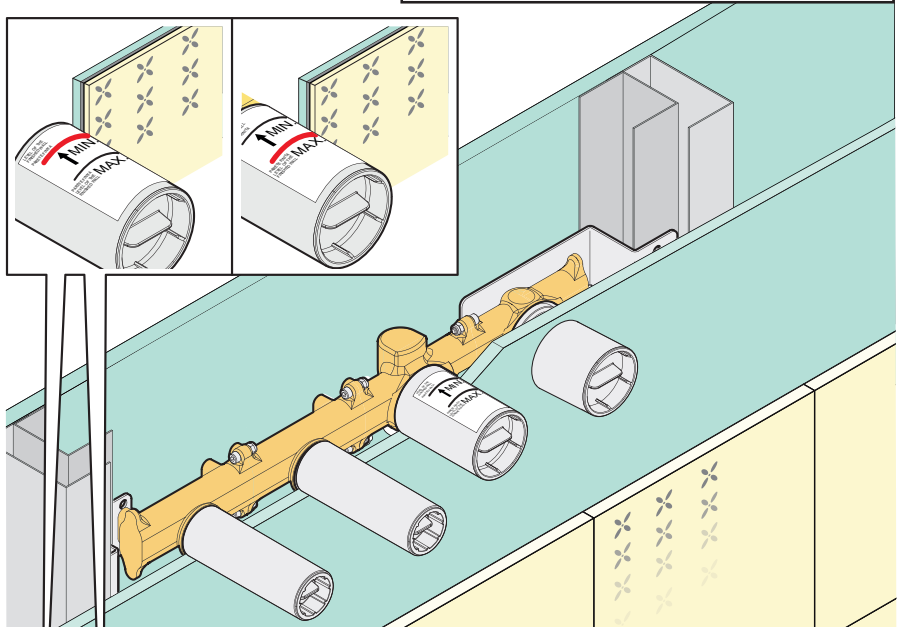

MIN
 MAX
 Filo rivestimento
 Edge of the tiling
 Fil revetement
 Verkleidungskante
 Borde revestimiento
 Alinhamento do revestimento

MIN= profondità minima / minimum depth / profondeur minimale
 minimale tiefe / profundidad mínima / profundidade mínima
 MAX= profondità massima / maximum depth / profondeur maximale
 maximale tiefe / profundidad máxima / profundidade máxima

2

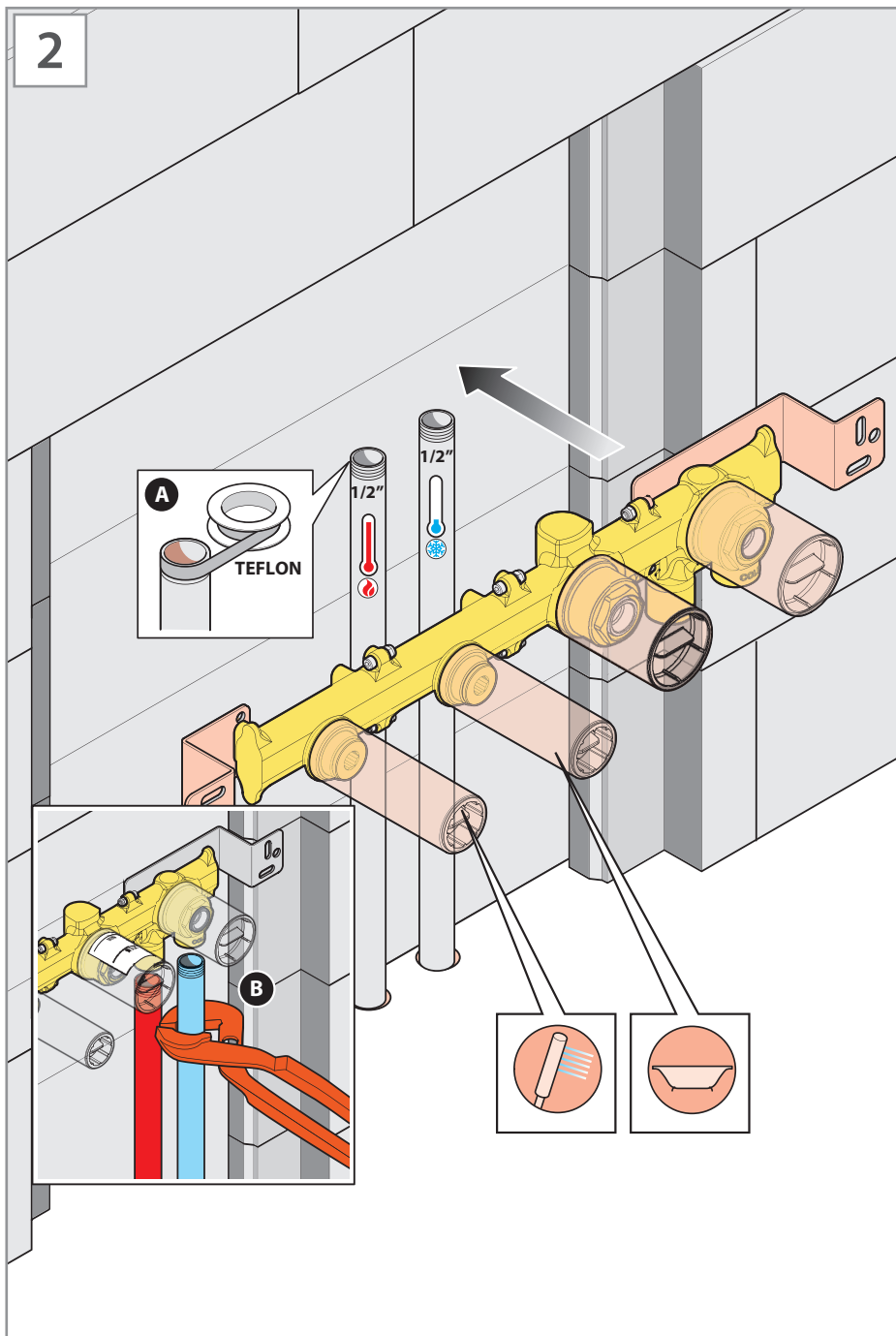

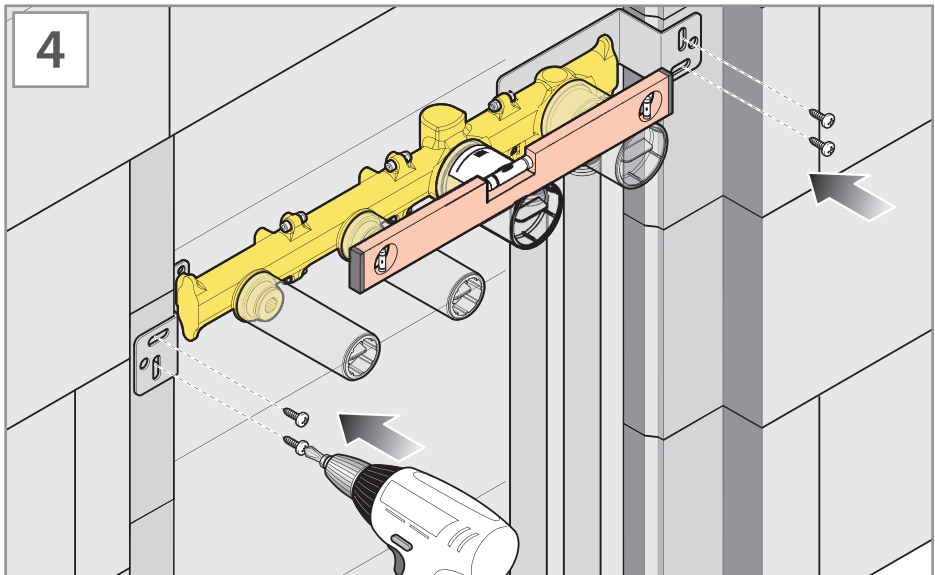
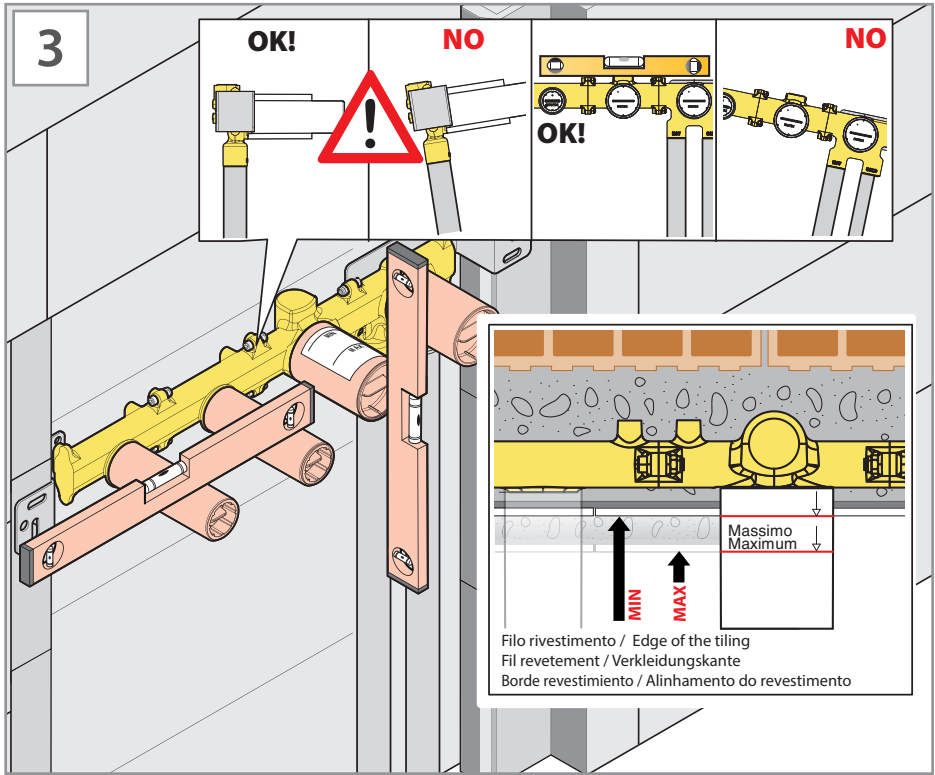

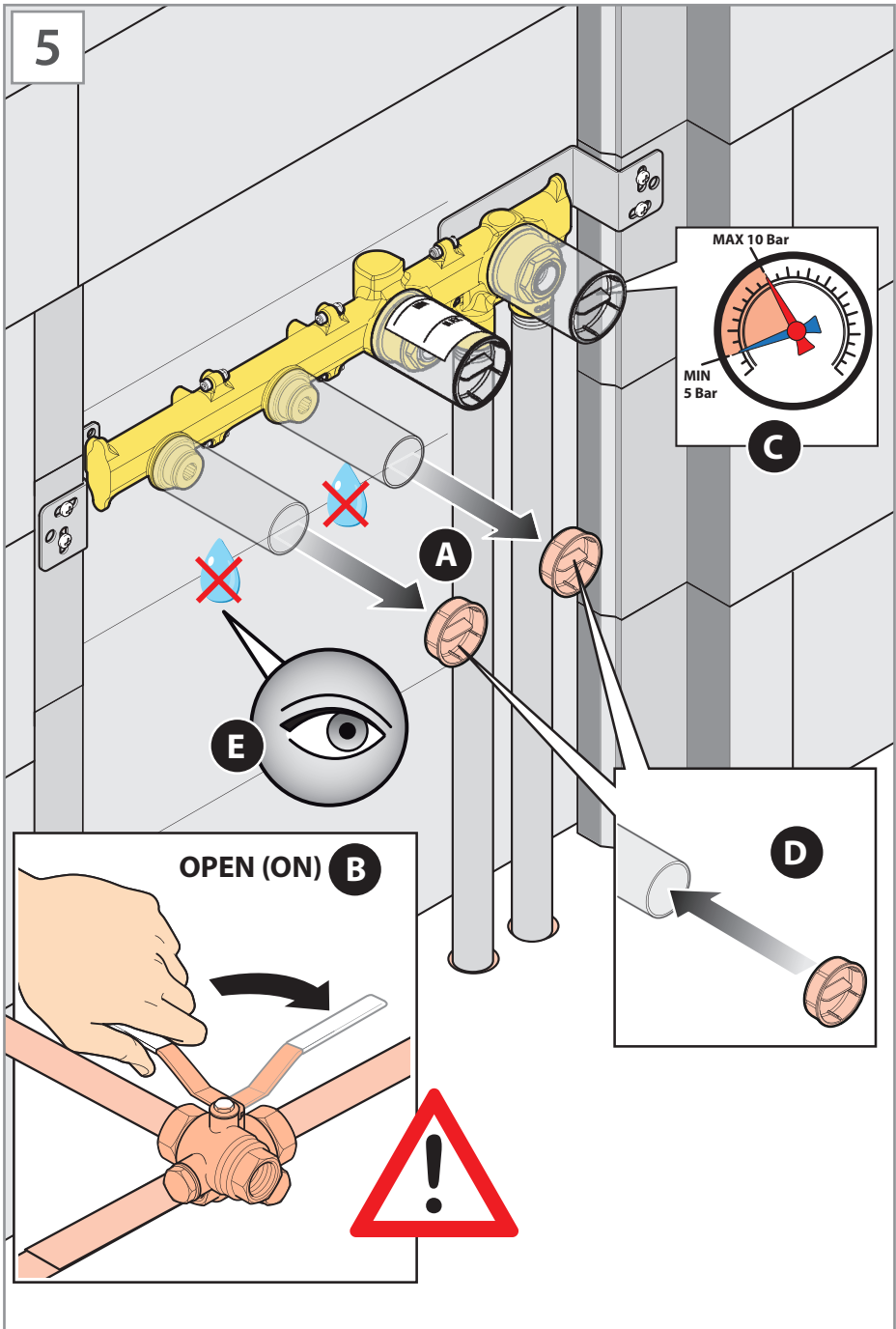

6

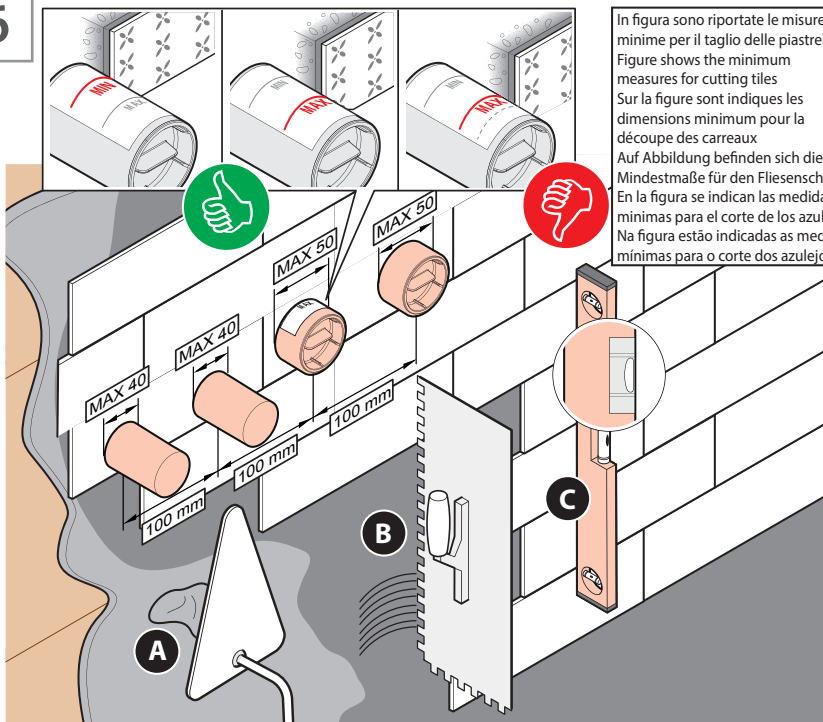

In figura sono riportate le misure minime per il taglio delle piastrelle
 Figure shows the minimum measures for cutting tiles
 Sur la figure sont indiqués les dimensions minimum pour la découpe des carreaux
 Auf Abbildung befinden sich die Mindestmaße für den Fliesenschnitt
 En la figura se indican las medidas mínimas para el corte de los azulejos
 Na figura estão indicadas as medidas mínimas para o corte dos azulejo

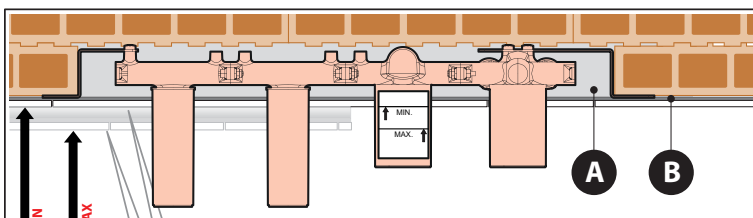

MIN= profondità minima / minimum depth / profondeur minimale
 minimale tiefe / profundidad mínima / profundidade mínima
 MAX= profondità massima / maximum depth / profondeur maximale
 maximale tiefe / profundidad máxima / profundidade máxima

C Filo rivestimento
 Edge of the tiling
 Fil revetement
 Verkleidungskante
 Borde revestimiento
 Alinhamento do revestimento

A Intonaco - Plaster - Enduit - Putz - Enlucido - Reboco

B Collante - Bonding agent - Colle - Fliesenkleber - Cola - Cola



7

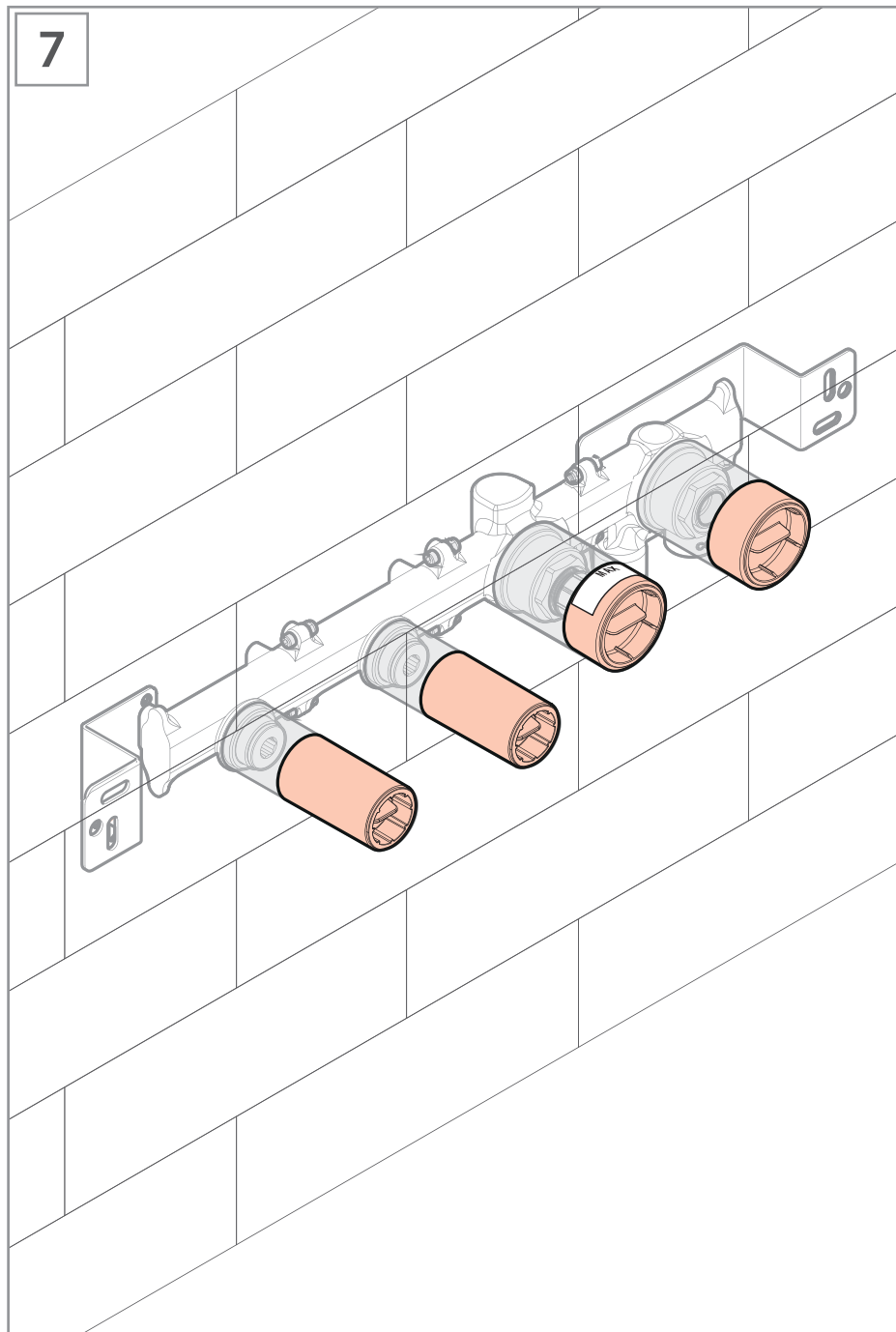

EFEZ027

8

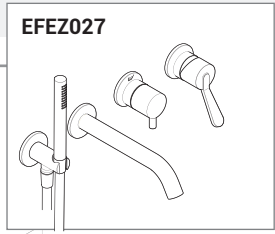
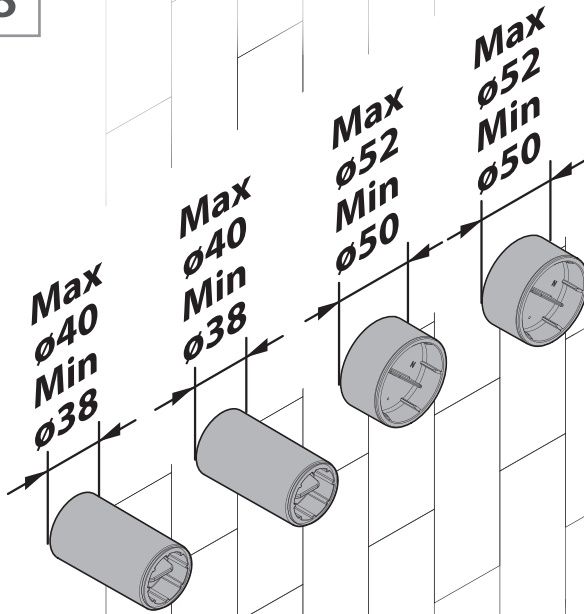

9

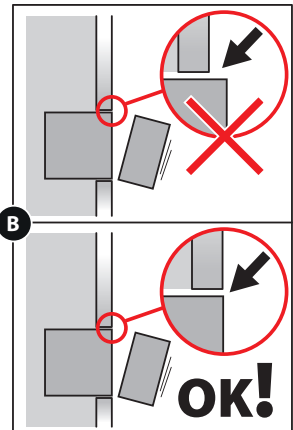
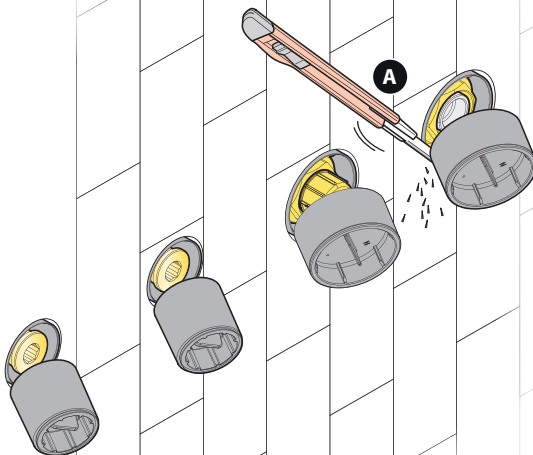

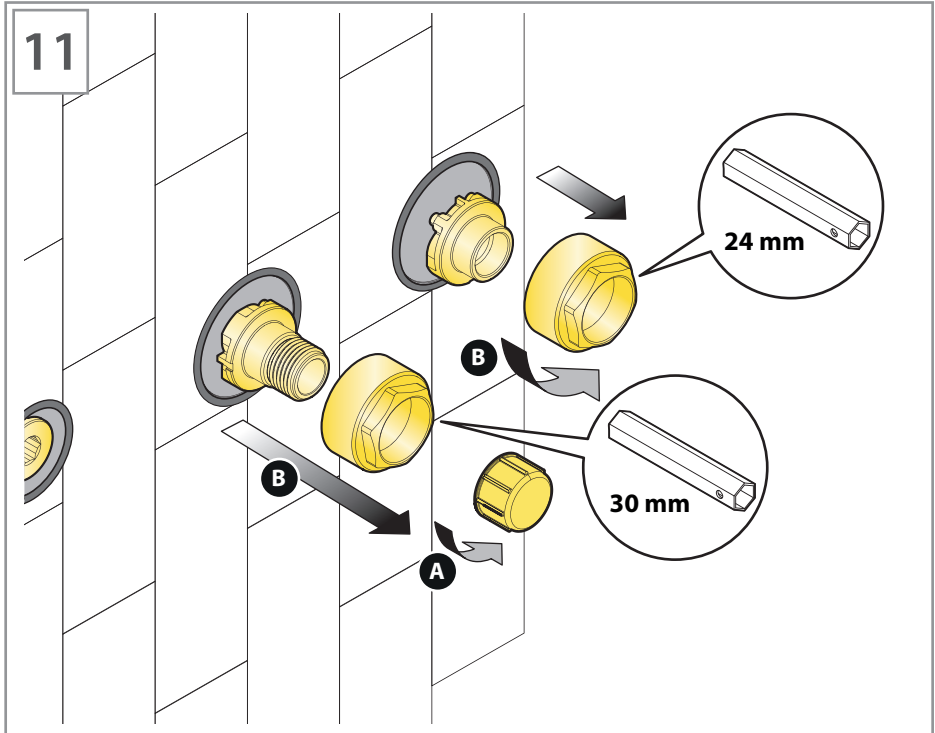
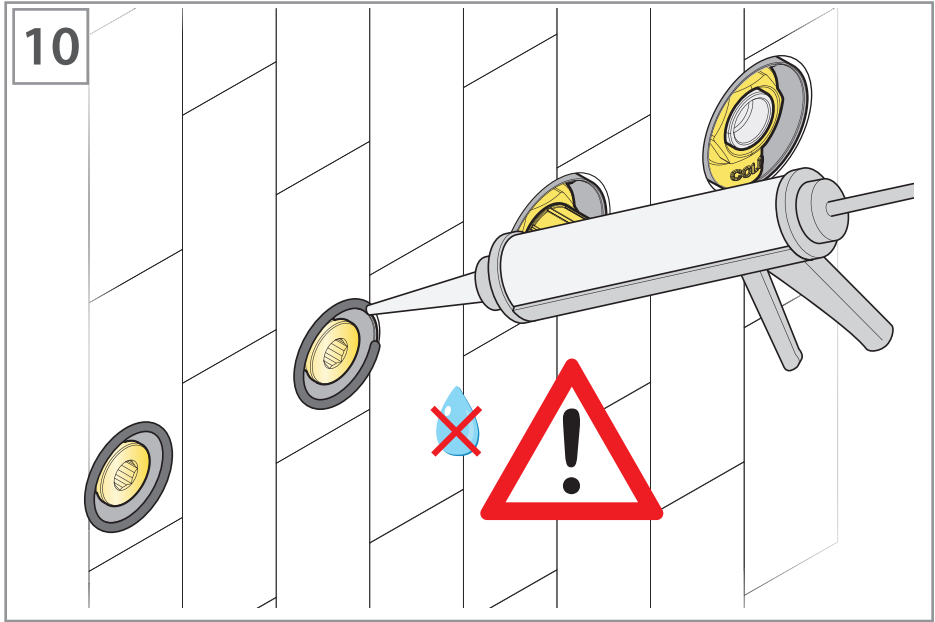

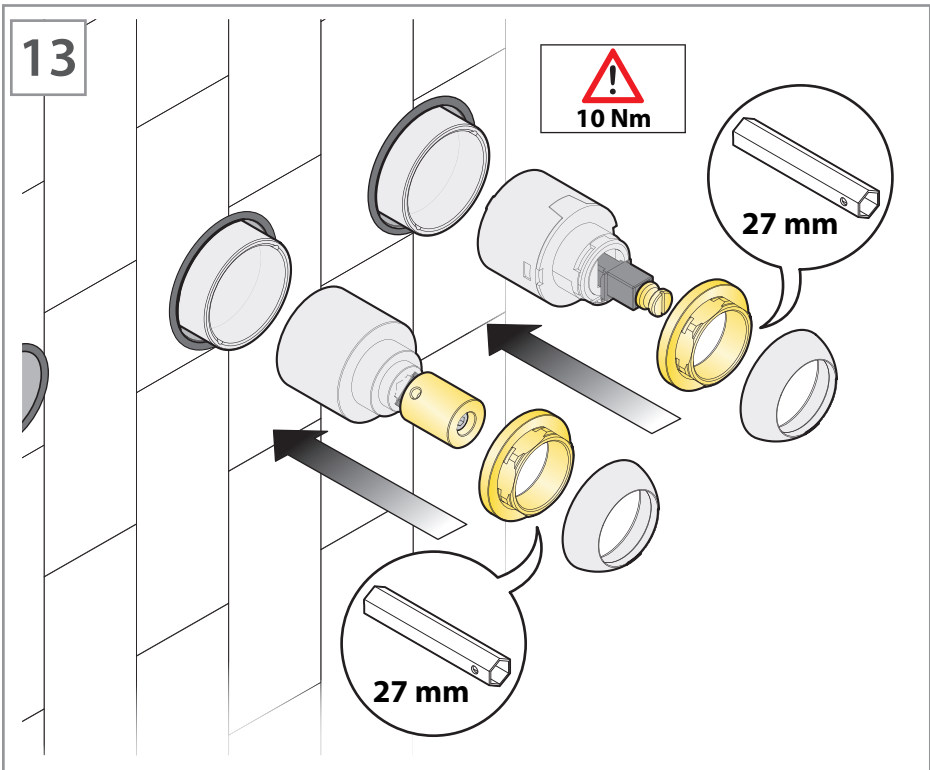
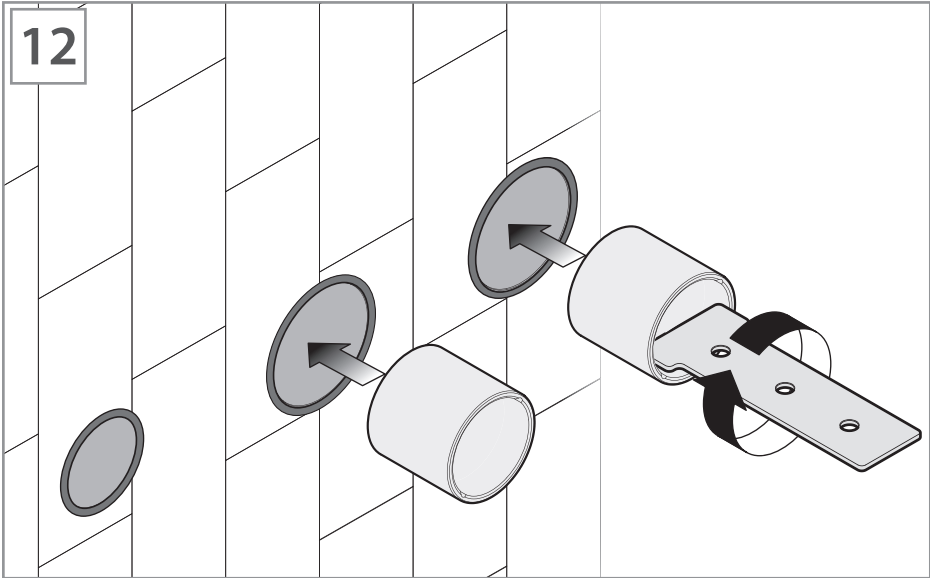

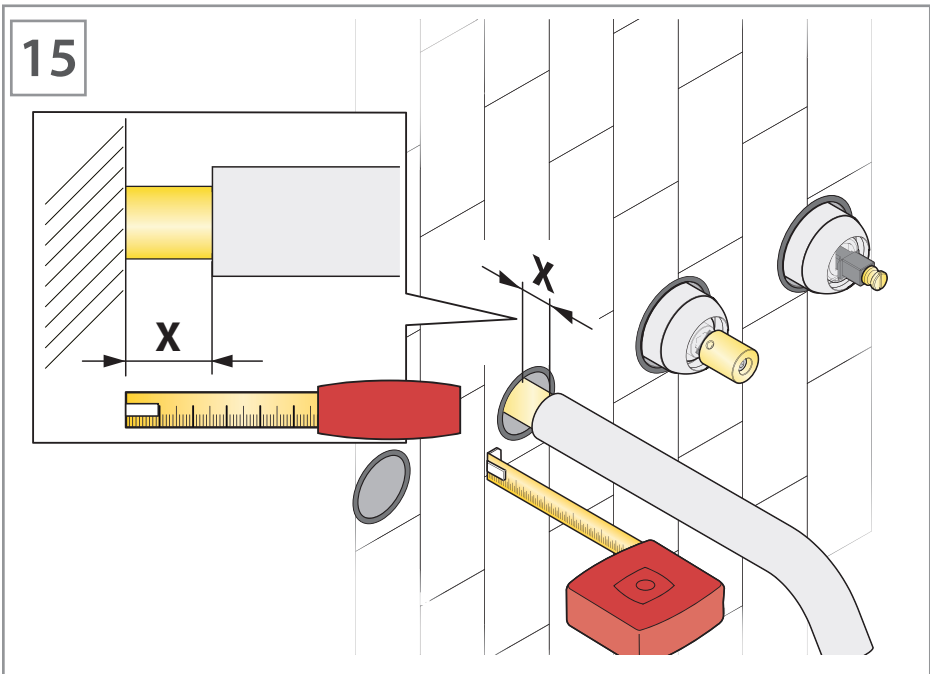
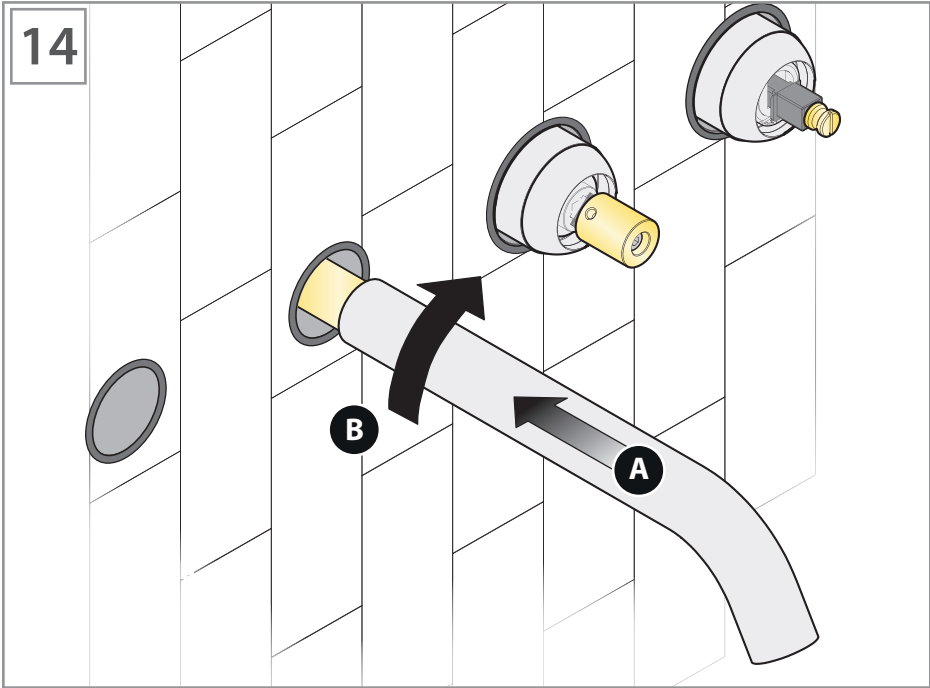

16

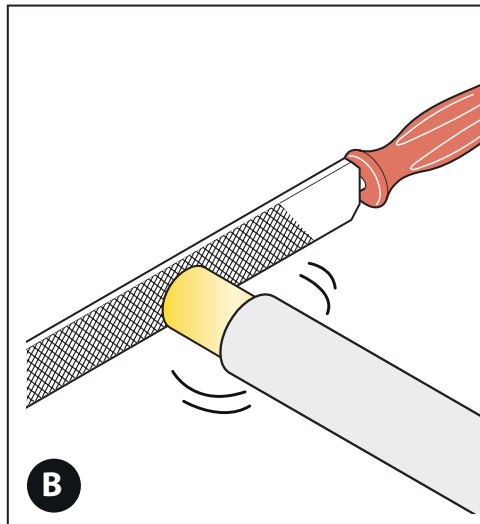
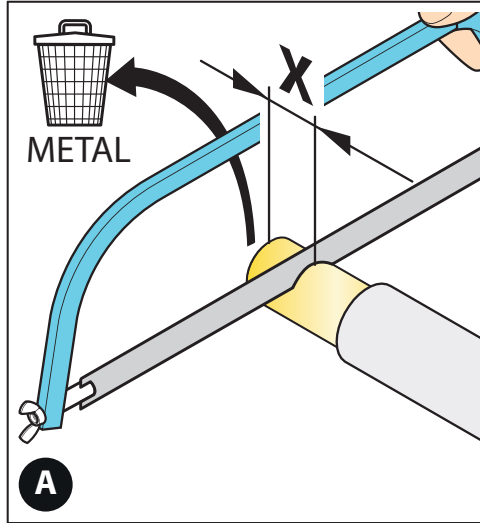

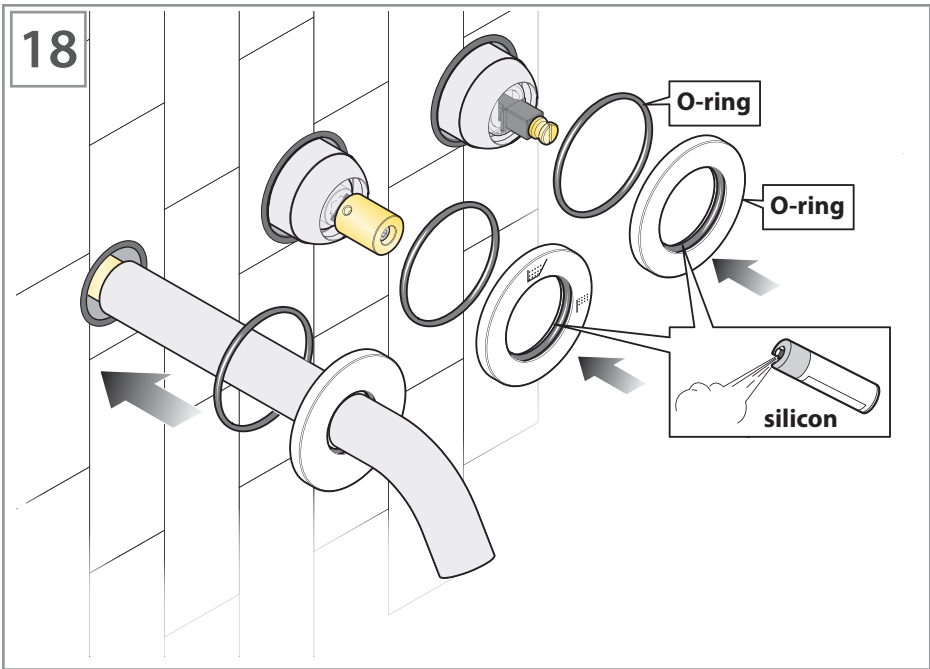
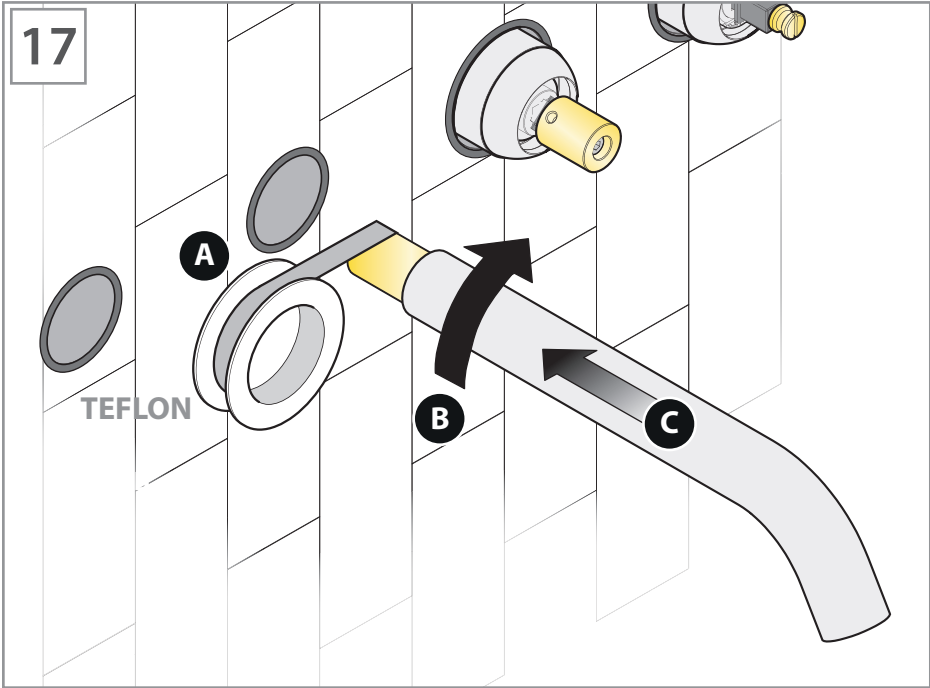



19

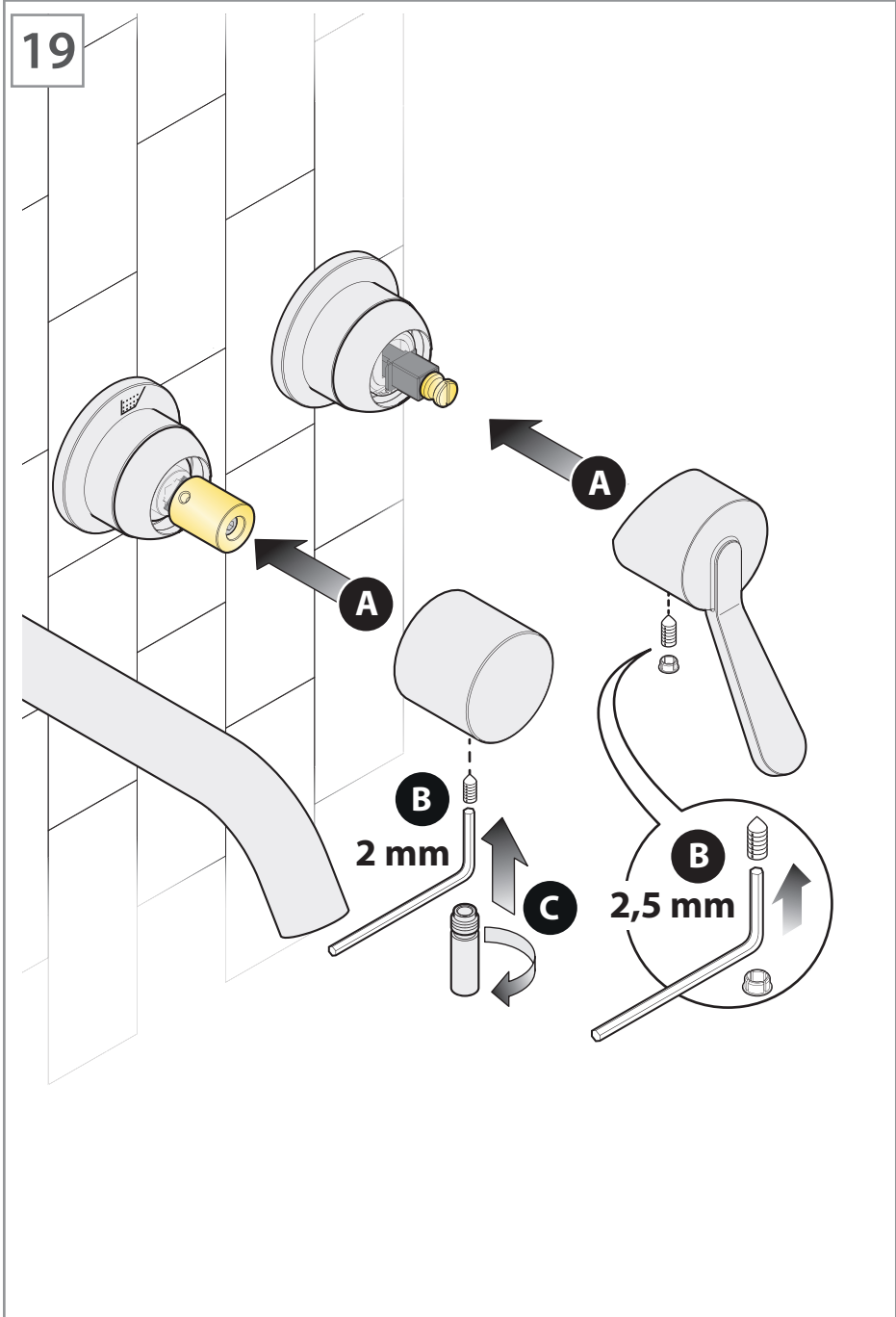

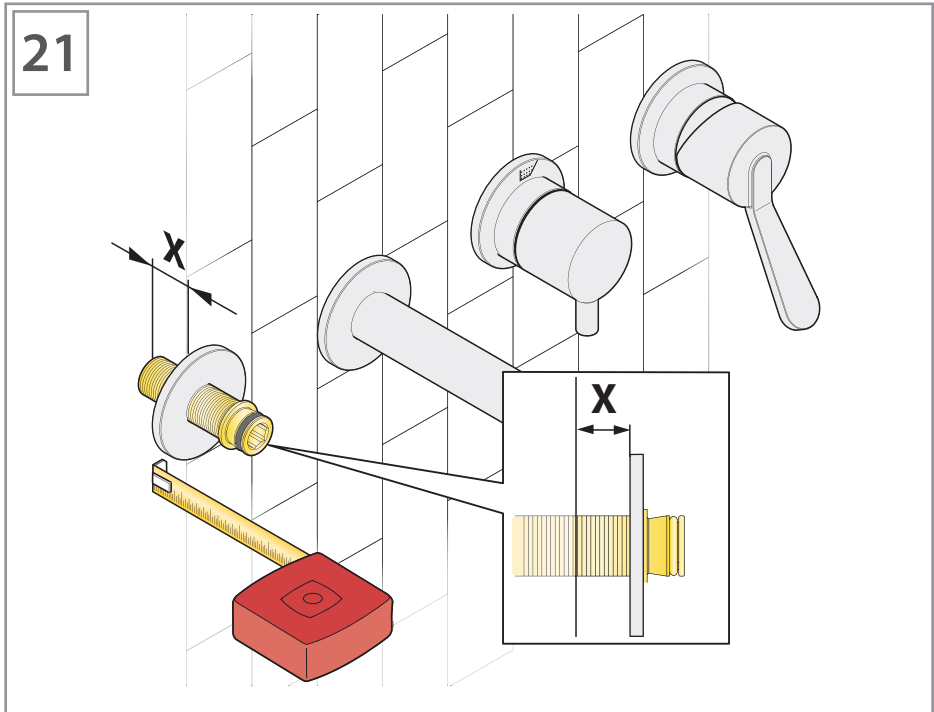
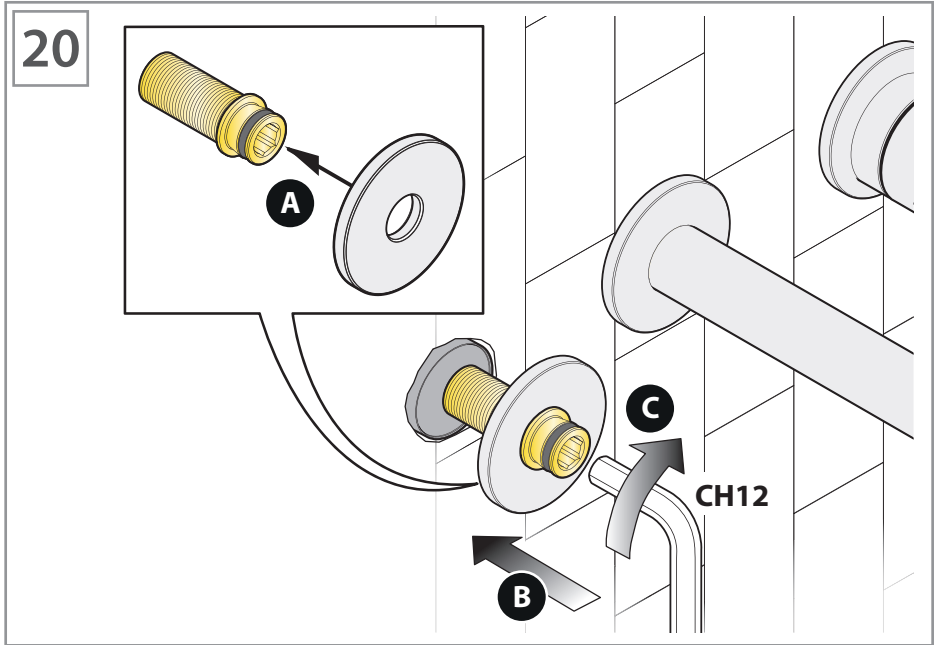

22

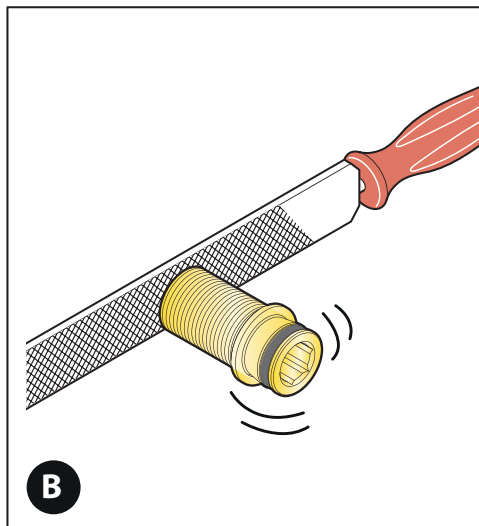
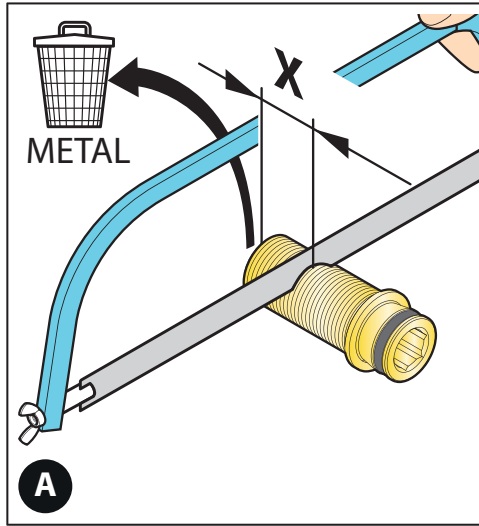

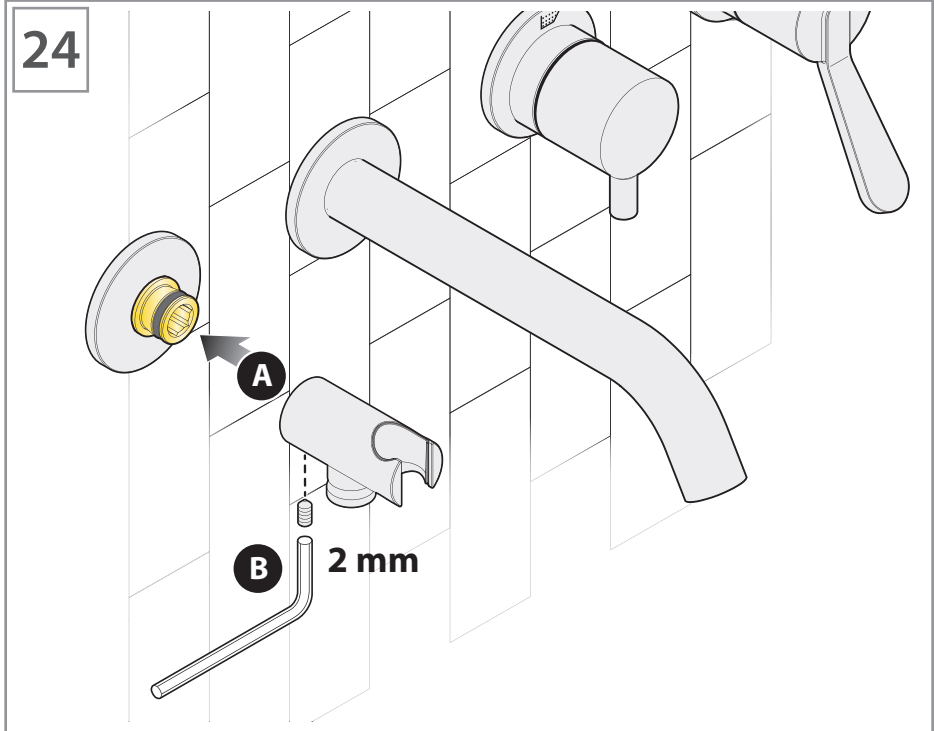
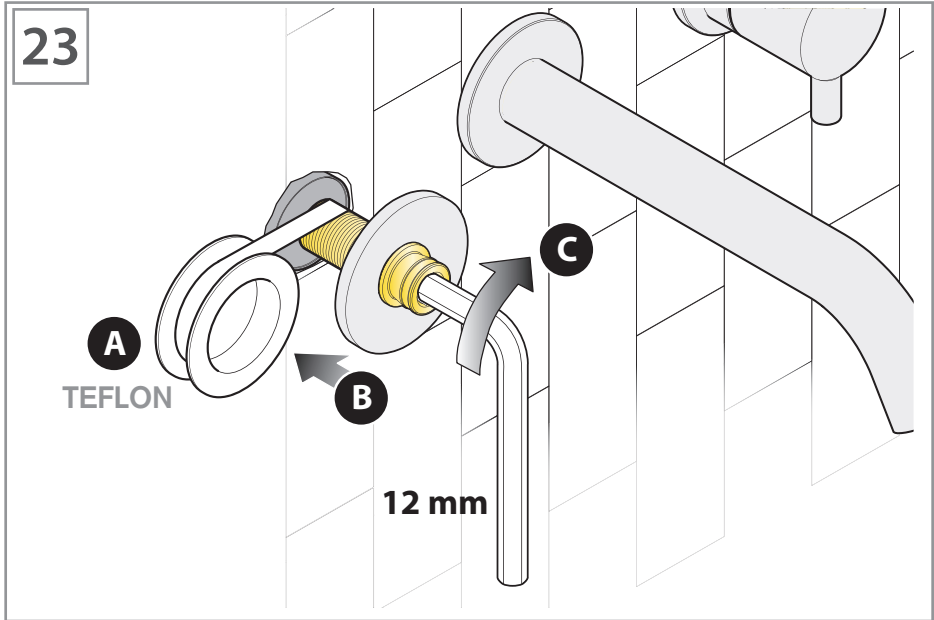

25

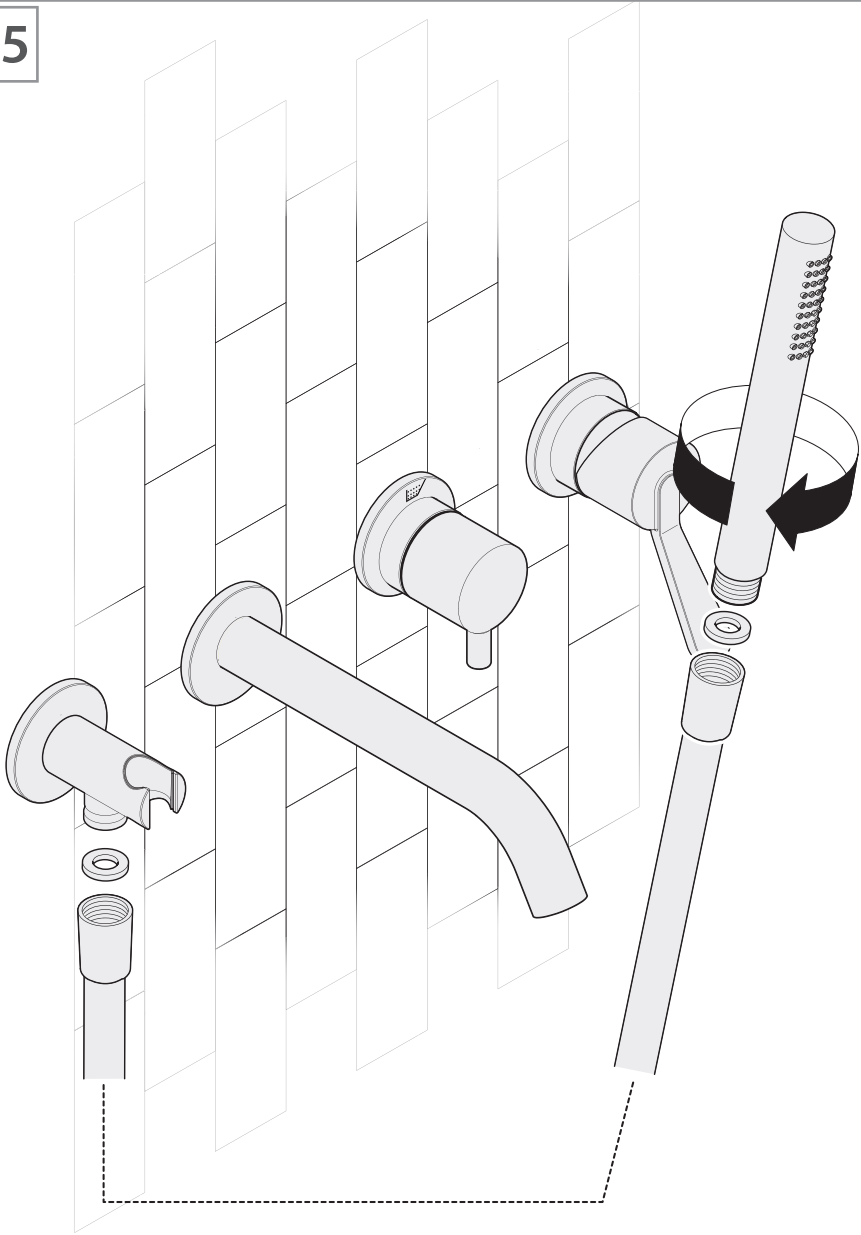

26

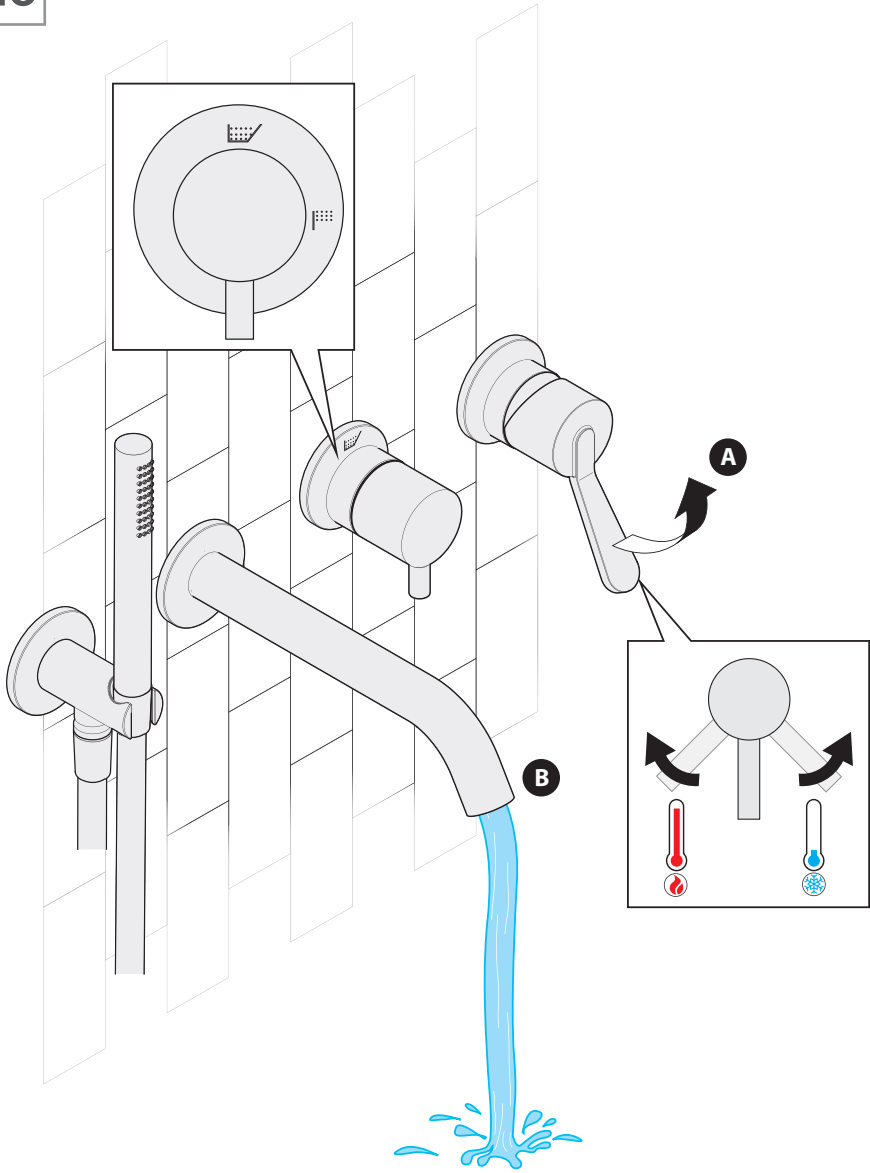

27

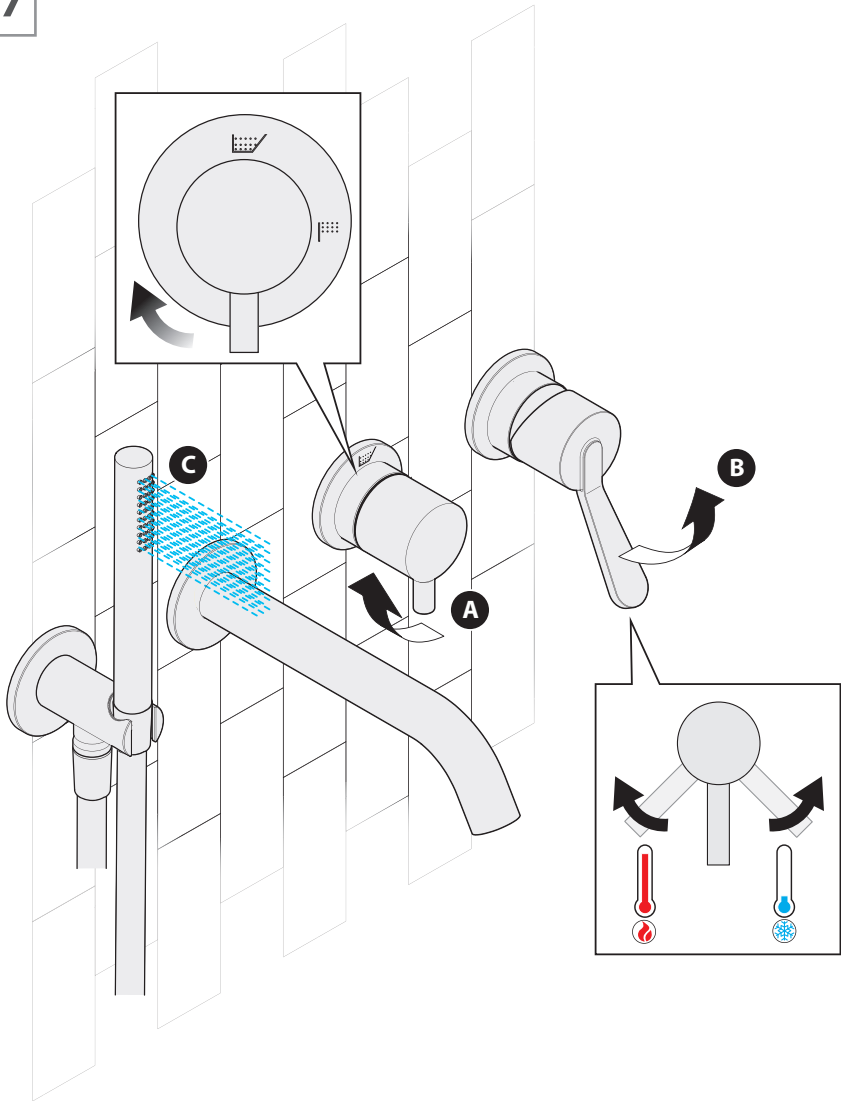

- IT** Al primo utilizzo o dopo un lungo periodo di inutilizzo, non consumare il primo mezzo litro di acqua potabile erogata. Chiudere l'impianto idraulico in caso di prolungata assenza.
Controllare periodicamente la tenuta.
- EN** On first use or following prolonged periods of inactivity, do not use the first half-litre of drinking water dispensed. Shut off the plumbing system in the event of a long absence.
Check the water-tightness regularly.
- FR** Lors de la première utilisation ou après une longue période de non utilisation, ne pas consommer le premier demi-litre d'eau potable qui sort du robinet. Fermer l'installation hydraulique en cas d'absence prolongée. Contrôler périodiquement l'étanchéité.
- DE** Schütten Sie bei Erstbenutzung oder nach einem längeren Zeitraum der Nichtbenutzung den ersten halben Liter Trinkwasser weg. Stellen Sie das Wasser bei längerer Abwesenheit ab.
Prüfen Sie in regelmäßigen Abständen die Dichtheit.
- ES** Durante el primer uso o tras un largo periodo de inactividad, no consumir el primer medio litro de agua potable que salga del grifo. Cerrar la instalación de agua si va a estar ausente durante un largo periodo. Comprobar periódicamente que no haya pérdidas
- PT** Na primeira utilização ou após um longo período de inutilização, não consuma o primeiro meio litro de água potável distribuída. Feche o circuito hidráulico no caso de ausência prolongada.
Verifique periodicamente a vedação.

IT La pulizia delle superfici va fatta utilizzando un panno morbido imbevuto con sapone liquido diluito in acqua: al termine risciacquare e asciugare con cura.

Non usare in nessun caso detersivi contenenti sostanze abrasive o a base di acido muriatico, aceto, ammoniaca, acetone, candeggina, acidi di uso domestico, disinfettanti vari o spugne abrasive.

ATTENZIONE! L'impiego di prodotti non consigliati può deteriorare irrimediabilmente le superfici, nel qual caso il produttore non risponderà del danno.

In caso di diminuzione dell'erogazione pulire o sostituire l'aeratore situato tra la doccetta ed il flessibile.

EN Clean the surfaces using a soft cloth soaked in liquid soap diluted in water, then rinse and dry thoroughly.

Never use detergents containing abrasive substances or containing muriatic acid, vinegar, ammonia, acetone, bleach, domestic acids, disinfectants in general or abrasive sponges.

CAUTION! The use of products other than those recommended may damage the surfaces irreparably, in which case the manufacturer will not be held liable.

If the flow rate decreases, clean or replace the aerator between the hand shower and the flexible hose.

FR Nettoyer les surfaces avec un chiffon doux imbibé de savon liquide dilué dans l'eau : à la fin, rincer et essuyer avec soin.

Ne jamais utiliser de détergents contenant des substances abrasives ou à base d'acide chlorhydrique, vinaigre, ammoniac, acétone, eau de javel, acides à usage domestique, désinfectants divers, ni d'éponges abrasives.

ATTENTION ! L'emploi de produits non conseillés peut détériorer irrémédiablement la surface des articles pour lesquels le fabricant ne sera pas responsable.

Au cas où la sortie d'eau diminuerait, nettoyer ou remplacer l'aérateur situé entre la douchette et le flexible.

DE Reinigen Sie die Oberfläche mit einem weichen Tuch, das in Wasser mit Flüssigseife eingetaucht wird; anschließend mit Wasser spülen und gründlich abtrocknen.

Verwenden Sie auf keinen Fall Reinigungsprodukte, die Scheuerstoffe, Salzsäure, Essig, Ammoniak, Aceton oder Bleichlaug enthalten; vermeiden Sie ebenso Säuren aus häuslicher Verwendung, Desinfektionsmittel und Scheuerschwämme.

ACHTUNG! Die Verwendung dieser nicht empfohlenen Produkte kann die Oberflächen unwiederbringlich beschädigen; der Hersteller haftet in diesem Fall nicht für Schäden.

Bei einer Verringerung des Strahls muss der zwischen Handbrause und Schlauch positionierte Strahlregler gesäubert oder ausgewechselt werden.

ES Las superficies deben limpiarse con un paño suave y jabón líquido diluido en agua: al finalizar, aclarar y secar con cuidado.

No utilizar en ningún caso detergentes que contengan sustancias abrasivas o a base de ácido clorhídrico, vinagre, amoníaco, acetona, lejía, ácidos de uso doméstico, desinfectantes varios o esponjas abrasivas.

¡ATENCIÓN! El uso de productos no recomendados puede ocasionar un deterioro irreparable de las superficies, en cuyo caso el fabricante no se responsabilizará de los daños.

Si disminuye el caudal de agua suministrado, limpiar o cambiar el aireador situado entre la ducha y el flexo.

PT A limpeza das superfícies deve ser feita utilizando um pano macio humedecido com sabão líquido diluído em água: no fim enxagúe e seque bem.

Não use, em caso algum, detergentes com substâncias abrasivas ou à base de ácido muriático, vinagre, amoníaco, acetona, lixívia, ácidos de uso doméstico, desinfetantes ou esponjas abrasivas.

ATENÇÃO! A utilização de produtos não recomendados pode danificar irremediavelmente as superfícies, nesse caso o produtor não se responsabiliza pelo dano.

Se a distribuição de água diminuir limpe ou substitua o emulsor situado entre a bica e o tubo flexível.





2019 © agape srl

via Po Barna, 69 - 46031
Correggio Micheli Bagnolo San Vito
Mantova - Italia
tel. +39 0376 250311
fax. +39 0376 250330
mail. info@agapedesign.it

1121000130000000 Rev.0

